

4-CHANNEL RECEIVER

# QX-9900

FW



OPERATING INSTRUCTIONS

 **PIONEER**<sup>®</sup>

## FEATURES

### PLAYBACK OF DISCRETE 4-CHANNEL PROGRAMS POSSIBLE

As model QX-9900 incorporates 4-channel control amplifiers and power amplifiers, discrete 4-channel programs such as tapes and "QUAD 8" cartridges can be played. Discrete 4-ch. phonograph discs—so-called CD-4 records—can be played with the help of a decoder.

### EQUIPPED FOR ALL MATRIX SYSTEMS

Decoding circuits are provided for both regular 4-channel matrix and SQ matrix records.

### 4-CHANNEL EFFECT FROM 2-CHANNEL STEREO SOURCES

Rear channel signals can be extracted from conventional 2-ch. stereo records, FM stereo broadcasts and tapes, with the help of the QX-9900's built-in matrix decoder circuit. These features bring to life a great deal of previously concealed impact and beauty in your existing tapes and records.

### CONVENTIONAL 2-CHANNEL OPERATION POSSIBLE, TOO

If desired, all programs can be played in the conventional 2-channel stereo way.

### BUILT-IN REVERBERATION UNIT

An echo-like reverberation effect can be added to any program, thanks to the built-in reverberation unit. Reverberation time is freely adjustable, the reverb effect can be imposed on either the front speakers, the rear speakers, or on microphone sound.

### SIMULTANEOUS 4-CHANNEL LISTENING IN TWO SEPARATE ROOMS

As a total of eight speakers can be connected, it is possible to enjoy 4-channel sound in two separate rooms, or to create an intricate 4-channel 8-speaker sound field arrangement in a large listening room.

### OUTPUT LEVEL METERS FOR ALL FOUR CHANNELS

Four level meters are provided, indicating the amplifier output to the four channels. This is helpful in obtaining optimum balance and to remember optimum control settings for various programs. The meters can also be used for a variety of measurements. Meter sensitivity can be adjusted in 4 steps for accurate readings in any range.

### PROVISIONS FOR CONNECTING TWO TAPE DECKS

With two tape decks connected, tapes can be duplicated and edited with great ease.

### FULLY EQUIPPED WITH AUXILIARY CONTROLS AND CONNECTORS FOR ALL PURPOSES

These include: Separate headphone jacks for front and rear. Separate bass and treble controls for the front and rear channels. Individual loudness switches for front and rear. -20dB audio muting switch. FM MPX noise filter, FM muting. Front left-right, rear left-right and front-rear balance controls. Provision for using the preamplifier and power amplifier stages separately.

### ADDING OF LIVE SOUND VIA ONE OR TWO MICROPHONES

The sound of one or two microphones can be blended into any music program, for instance to make announcements or to sing along with the music.

### HIGH GRADE CIRCUIT DESIGN IN ALL SECTIONS

For sensitive, clear FM reception, the tuner is equipped with two FETs, several ICs and ceramic filters. The MPX stereo decoder is of the time switching type and guarantees sharp, stable channel separation of FM stereo broadcasts. For quick, easy tuning, a signal strength meter and a center-zero tuning meter are provided, and the FM scale is linear (meaning that frequencies are spaced out evenly over the scale).

In the power amplifier, a pure complementary OCL circuit design is used for optimum stability, freedom from transient and harmonic distortions, and super-wide power bandwidth.

### LOOKS AS IMPRESSIVE AS IT SOUNDS

To this 4-channel receiver, the word "compact" can not be applied—it is a rather large, impressive looking unit whose outward appearance already hints at its superb performance and versatility. The dial and meter section is angled backward for easier reading, program and channel indicator lamps light up according to operation mode, and the unit comes installed in a luxurious oiled-walnut cabinet.

## COMPOSITION OF A 4-CHANNEL STEREO SYSTEM

To compose an ideal 4-channel stereo system, the QX-9900, a solid state AM/FM stereo receiver, can be combined with four speaker systems, tape decks, turntables, microphones, etc. as shown in Fig. 1.

If electronic crossover network (separately available Pioneer SF-500 or SF-700) is installed as shown in Fig. 2, a 2-channel 2-way multi-amplifier system can be set up.

## PERFORMANCE OF QX-9900

### 4-CHANNEL STEREO PERFORMANCE

With a 4-channel stereo tape deck or cartridge tape player installed, the QX-9900 can provide a discrete 4-channel playback of programs recorded on tape.

### 4-CHANNEL REPRODUCTION FROM MATRIX 4-CHANNEL SOURCE

The self-contained matrix circuit permits 4-channel reproduction from matrix 4-channel records or FM stereo broadcasts. The mode switch has positions for regular matrix and SQ matrix reproduction, allowing reproduction to take either of these forms.

### MATRIX REPRODUCTION FROM 2-CHANNEL STEREO SOURCE

A 2-channel signal from a record or FM broadcast can be reproduced in 4-channel form via the regular or SQ matrix circuit. In this case, the result is an improvement over ordinary 2-channel stereo reproduction.

### 2-CHANNEL STEREO PERFORMANCE

Conventional 2-channel stereo performance can be provided through the two speaker systems in the front; left-side speaker system and right-side speaker system. A 2-way multi-amplifier system can be set up by adding an electronic crossover network (see Fig. 2).

### REVERBERATION EFFECT CAN BE ADDED

An echo-like reverberation effect can be added either to the front channels, the rear channels or the microphone sound; for this purpose, a special reverberation mode switch is provided. What's more, the duration of this reverberating effect can be controlled at will with the time control.

### MICROPHONE SOUND CAN BE ADDED TO ANY PROGRAM

By connecting one or two microphones, announcements, etc. can be blended into any broadcast, record or tape program. (Microphone sound cannot be recorded on tape via the TAPE REC outputs, though.) With two microphones, live stereo effects are obtainable.

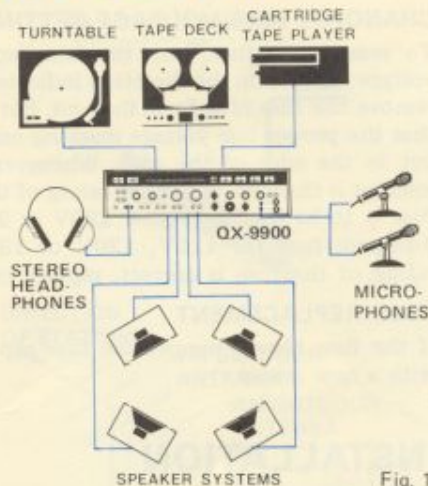

Fig. 1

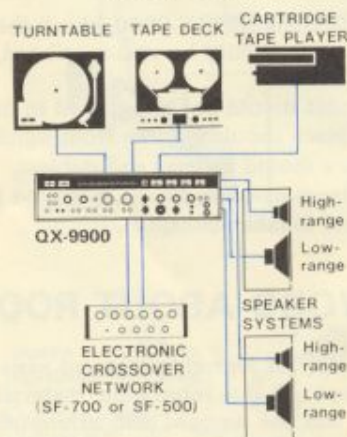

Fig. 2

## LINE VOLTAGE AND FUSE

### CHANGING LINE VOLTAGE SETTING AND FUSE

To remove the fuse, turn the fuse cap located on the line voltage selector in the direction indicated by the arrow. Then remove the fuse plug from the unit. Put the fuse plug back so that the proper line voltage marking can be seen through the cut in the edge of the plug. Whenever the position of the selector is changed, check the rating of the fuse. A 2.5-ampere fuse is to be used for either 220V or 240V operation and a 5-ampere fuse for 110V, 120V or 130V operation. If the rating of the fuse is correct, replace cap.

### FUSE REPLACEMENT

If the fuse blows, remove the fuse cap and replace the fuse with a new one.

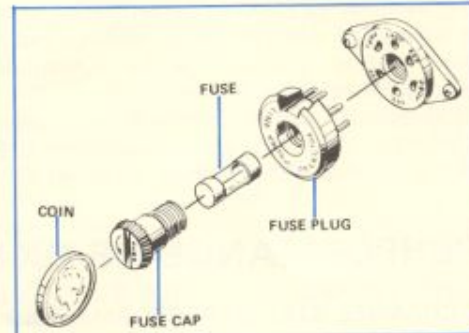

Fig. 3

## INSTALLATION

When installing the QX-9900, check the following points:

- The place should be well-ventilated, and free from dampness and dust.
- The unit should not be exposed to direct sunlight.
- The place should be free from significant vibration, or the surface should be level and stable.
- The large-size, weighty unit should be placed on a shelf or a stand durable enough.

## A WORD ABOUT ROOM ACOUSTICS

The quality of reproduced sound varies according to the size and shape of the room, the materials of walls, floor and ceiling and the amount and arrangement of furniture. Too harsh or "bright" a sound usually results from too many hard reflecting surfaces, and/or too low a ceiling. This condition is improved by having ample carpeted area or covering the wall (especially that facing the speakers) with a thick curtain. On the other hand, too many absorbing surfaces will tend to "soak up" the sound, resulting in a certain "deadness." Furniture may be rearranged to provide irregular reflection of the sound. In any event, the true stereo effect is lost if the two speaker systems are placed too far apart. This may be corrected by angling them slightly toward each other or reducing the distance between them.

## ANTENNA AND GROUND CONNECTIONS

### FM ANTENNA

FM broadcast signals are obstructed somewhat by mountains, buildings, and other obstacles. Therefore, even if a station is nearby, a high-gain antenna may be required. Select the antenna in accordance with the following:

- If the receiver is to be located in a wooden building and stations are nearby, use the T-type antenna which comes with the QX-9900. As shown in Fig. 4, connect the feeder terminals of the antenna to the FM antenna terminals. Stretch out the antenna proper and secure it to the ceiling or a wall in such a manner that pickup is optimum, as determined by listening to the stations to be received. Refer to FM RECEPTION on page 12.
- If orientation of the T-type antenna does not eliminate background noise, connect an outdoor antenna to the antenna terminals as shown in Fig. 5. In place of a special antenna, a combination FM/TV antenna may be used.

**NOTES:**

- A variety of FM antennas are available. Consult your sales dealer.
- In locations adjacent to heavily traveled streets, around factories, or near high-voltage power transmission lines, use of an FM antenna may not give the desired noise attenuation. In such cases, consult your sales dealer concerning a coaxial cable feeder (75Ω) for the FM antenna. When coaxial cable is used, make connections to the QX-9900 as shown in Fig. 6.

### AM ANTENNA

- Refer to AM RECEPTION on page 12. With an AM station tuned in, position the ferrite antenna for optimum pickup. See Fig. 7.
- If the ferrite antenna does not give satisfying results, stretch out the AM lead antenna (vinyl-insulated wire) and connect it to the AM antenna terminal. Keep the other end of the antenna lead as high as possible.
- If use of the lead antenna does not yet give satisfying results, erect an outdoor antenna and connect it as shown in Fig. 5. Special construction is not required: Vinyl-insulated wire may be stretched between two masts or other supports.

### GROUNDING

- A ground lead may not be necessary for reception. Still, from the viewpoint of safety and elimination of noise, one should be used.

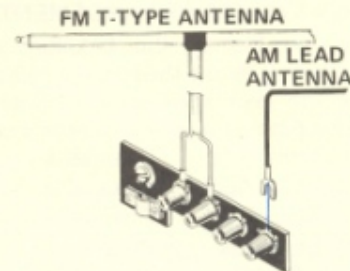

Fig. 4

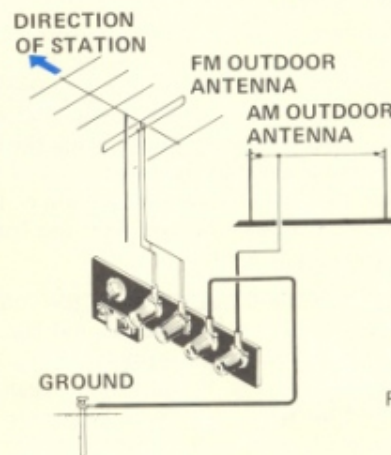

Fig. 5

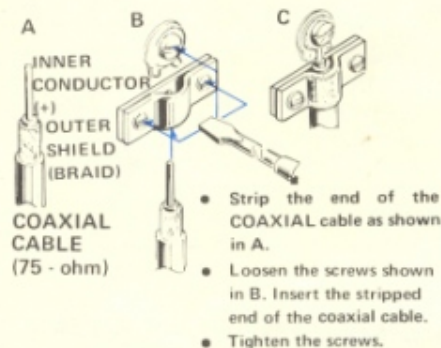

Fig. 6

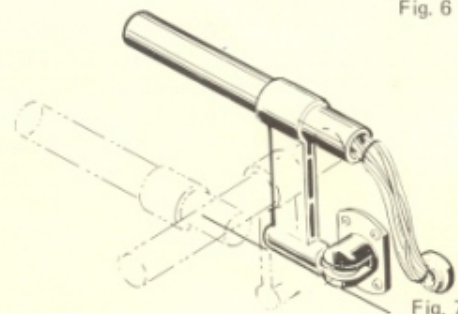

Fig. 7

## SPEAKER SYSTEM PLACEMENT AND CONNECTIONS

### SPEAKER SYSTEM ARRANGEMENTS

As shown in Fig. 8, the 4-channel system employs four speakers, one each on the left and right at the front and rear. Locating the rear speakers anywhere in the blue-shaded area of this figure will give an ample 4-channel effect.

Front left	Channel 1
Front right	Channel 3
Rear left	Channel 2
Rear right	Channel 4

### SPEAKER SYSTEMS

For the best 4-channel stereo performance, it is desirable to use four speaker systems having the same characteristics. If it is difficult to satisfy this requirement, it is suggested that speaker systems be selected and arranged as follows:

1. Select two speaker systems having the same characteristics, and arrange them in the front.
2. Select two speaker systems having as identical characteristics as possible compared with the front speaker systems.

### CONNECTIONS

1. As the QX-9900 has provision for connecting two pairs of 4-channel speaker systems (A and B), 4-channel reproduction in separate rooms is possible.
2. As shown in Fig. 9, accessory speaker plugs are used to connect the speaker systems. Be sure to observe the marked polarity (+, -). Do not short-circuit (+) and (-) terminals.
3. Connect one of the speaker systems to the speaker sockets marked A. Make sure that the speaker placed at the front left is plugged into the FRONT A CH 1 (L) socket, the speaker placed at the front right is plugged into the FRONT A CH 3 (R) socket, and that the speaker placed at the rear left is plugged into the REAR A CH 2 (L) socket, and that the speaker placed at the rear right is plugged into the REAR A CH 4 (R) socket. Note that any other arrangement will not give the 4-channel effect.
4. Connect the other speaker system to the speaker socket marked B, following the procedure outlined above.

## TURNTABLE CONNECTIONS

Connect the output from the turntable equipped with a moving-magnet phono cartridge to PHONO 1 input jacks. When two turntables are used at the same time, connect the second turntable to PHONO 2 input jacks. The upper jack is for the left channel, and the lower jack for the right channel.



Fig. 8

- NOTES:
1. For a better 4-channel stereophonic effect, it is suggested that speaker systems in the rear be placed on a level a little higher than your listening position.
  2. When listening to a 4-channel program source, arrange the four speaker systems as suggested for that particular program.

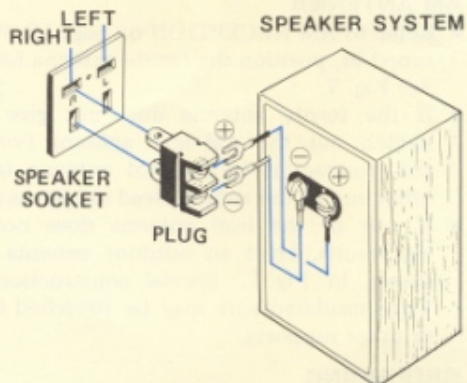

Fig. 9

- NOTES:
1. When using a turntable equipped with a moving-coil (MC) phono cartridge, use a head amplifier or separately available step-up transformer.
  2. Prepare a cartridge and decoder exclusively used for playing discrete 4-channel record. Plug the output jacks of the decoder into the AUX jacks.

## CARTRIDGE TAPE PLAYER CONNECTION

Connect the output cord of a cartridge tape player to either AUX 1 or AUX 2 input jacks.

- NOTES:**
1. When using a 2-channel stereo tape player, connect the left channel output to CH 1 of AUX input jacks, and the right channel output to CH 3.
  2. When using a 4-channel stereo tape player, follow the procedures as explained in the player manual.

### USE OF AUX 1 AND 2 JACKS

These jacks are spare input terminals. They may be used for connecting stereo output from a cartridge tape player, turntable with ceramic or crystal cartridge, or 4-channel record decoder, adding versatility.

## TAPE DECK (OR TAPE RECORDER) CONNECTIONS

### RECORDING

Connect the LINE INPUT of the tape deck to TAPE 1 REC output jacks of the QX-9900.

### PLAYBACK

Connect the LINE OUTPUT (or TAPE MONITOR) of the tape deck to TAPE 1 MON input jacks of the QX-9900.

- NOTES:**
1. For using a 2-channel stereo tape deck, connect the left channel input to CH 1 REC output jacks, left channel output to CH 1 MON input jacks, and connect the right channel input to CH 3 REC output jacks, right channel output to CH 3 MON input jacks. For using a 4-channel stereo tape deck, follow the procedures as explained in the tape deck manual.
  2. For using two tape decks at the same time connect the second tape deck to TAPE 2 REC and TAPE 2 MON jacks the same as in connection of one tape deck.
  3. For the above connections, use the connecting cord furnished with the tape deck.
  4. If the 2-channel stereo tape deck is equipped with a DIN-type REC/P.B. socket, connect this to the identical REC/P.B. socket on the QX-9900 using a REC/P.B. cord (optional Pioneer PP-101).

### TWO TAPE DECK CONNECTIONS FOR DUPLICATING OR EDITING A RECORDED PROGRAM

Connect two tape decks as described in RECORDING and PLAYBACK sections.

## CONNECTION DIAGRAM

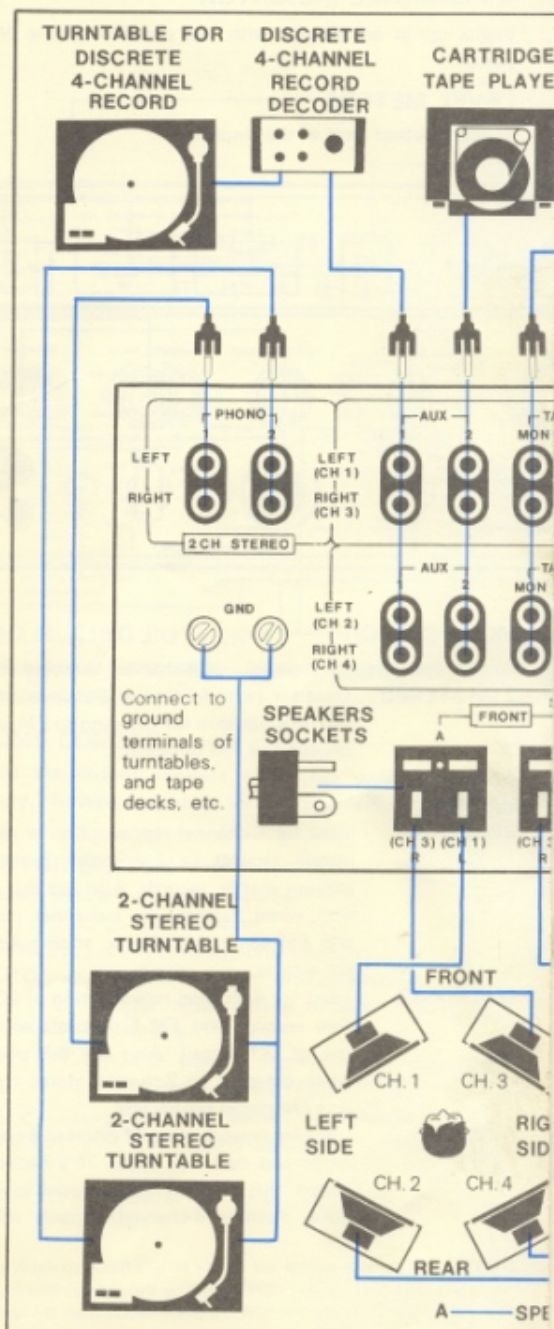





## FRONT PANEL FACILITIES 1

### POWER SWITCH

Push once to switch the power ON, once again to turn it OFF.

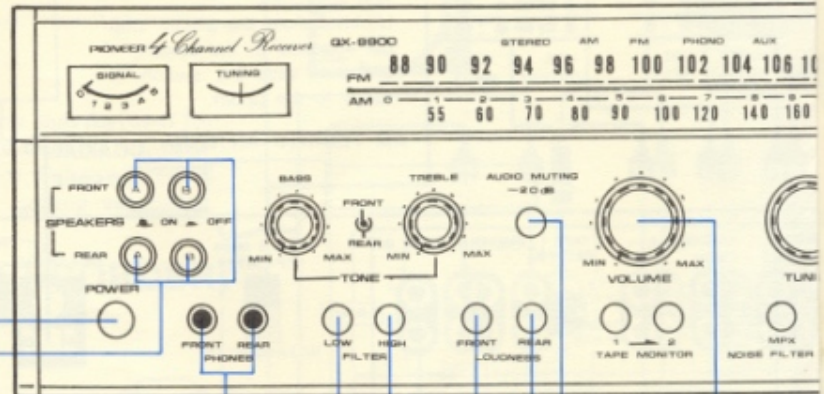

### SPEAKER SWITCHES

Up to four pairs of speakers can be connected and switched on and off (in pairs) with the SPEAKER switch buttons. Button released: respective pair of speakers in operation. Button depressed: respective pair of speakers off. (When released, these buttons light up.) For correlation with 2-channel or 4-channel mode, see explanations for MODE switch.

### PHONES JACKS

Plug the headphones into FRONT jack to hear the left and right front channels. Likewise, plug the headphones into REAR jack to hear in the left and right rear channels.

### FILTER BUTTONS

**LOW:** Use this filter to cut out low-frequency noise (hum, rumble).

**HIGH:** Use this filter to cut out high-frequency noise (hiss).

### LOUDNESS BUTTONS

The loudness circuit compensates for an apparent loss in very low and very high frequency ranges when the listening volume is rather low. At normal and high volumes, leave these buttons in OFF position (released). The left button functions on the front channels, the right button on the rear channels.

### AUDIO MUTING BUTTON

With this switch set to -20dB position, the output level is attenuated by 20dB.

### VOLUME CONTROL

Controls the output volumes of all four channels simultaneously. Turning the knob to the right will increase the volume.

### SELECTOR SWITCH

This switch selects the program source.

AM . . . . . AM reception.

FM MONO . . . . . FM monophonic reception only.

FM AUTO . . . . . FM reception, with automatic switching for either stereo or monophonic programs.

PHONO 1 . . . . . For playing records on a turntable plugged into the PHONO 1 jacks.

PHONO 2 . . . . . Same as above for PHONO 2 jacks.

AUX 1 . . . . . For playing signals fed to the AUX 1 jacks.

AUX 2 . . . . . Same as above for AUX 2 jacks.

## 4/2 CHANNEL INDICATOR

Lights up in accordance with the position of the MODE switch.

## LEVEL METERS

Indicate output level of the amplifier.

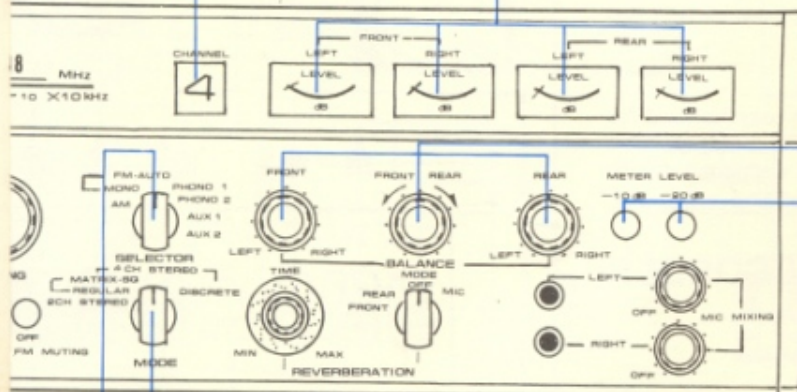

## MODE SWITCH

Selects the various 2-channel and 4-channel listening modes.  
**2 CH STEREO** . . . Used for reproduction of 2-channel stereo.  
Use this position for listening to FM monophonic and AM broadcasts.

## 4 CH STEREO

### MATRIX-

**REGULAR** . . . Used for 4-channel reproduction of regular matrix records or FM stereo broadcasts playing matrix records. Also use this position when listening to 2-channel records and FM stereo broadcasts, adding 4-channel effects.

**MATRIX-SQ** . . . Used for 4-channel reproduction of SQ system records and FM broadcasts with the use of SQ record. Also use this position when listening to 2-channel stereo records and FM stereo broadcasts.

**DISCRETE** . . . Used for reproduction of discrete 4-channel tapes and cartridge tapes. If a decoder is added, this position may be used to reproduce discrete 4-channel records (CD-4).

**NOTE:** With this switch set to 2 CH STEREO, sound from the rear left speaker (CH. 2) will be the same as that from the front left speaker (CH. 1) while sound from the rear right speaker (CH. 4) will be the same as that from the front right speaker (CH. 3). To hear the front speakers only, turn off the rear speakers by operating the SPEAKER switches.

## BALANCE CONTROLS

**FRONT** . . . . . Controls the relative volume of the front left and right channels.

**FRONT / REAR** . . . Controls the relative volume of the two front channels as opposed to the two rear channels.

**REAR** . . . . . Controls the relative volume of the rear left and right channels.

## METER LEVEL BUTTONS

Select meter sensitivity.

**-10dB:** Push this button, the level meters indicate 10dB more than actual output level. Therefore, subtract 10 from the meter reading to obtain actual output. E.g. when the meter is indicating -3dB, the actual output level is -13dB.

**-20dB:** Level meters indicate 20dB more than actual output level. Subtract 20 from the meter reading to obtain actual output.

**-30dB:** With both buttons pushed, the meters indicate 30dB more than actual output level.

**NOTE:** When -10dB and -20dB buttons are not pushed, the level meters indicate actual output level. A reading of 0dB indicates 35W per channel into an 8Ω load.

( Continued on pp. 11, 12. )

## PREPARATIONS BEFORE OPERATIONS

Confirm that the controls are in the following positions.

1. SPEAKERS switches (FRONT and REAR) at ON (not pushed).
2. BASS and TREBLE controls all at center.
3. AUDIO MUTING not pushed.
4. VOLUME control at MIN.
5. TAPE MONITOR switches (1 and 2) at OFF.
6. MODE switch at 2 CH STEREO.
7. All three BALANCE controls at center.
8. REVERBERATION MODE switch at OFF.
9. METER LEVEL buttons not pushed.
10. PRE & MAIN switch on the rear panel at INTERCOUPLED.

### CHANNEL CONFIRMATION

1. Set the SELECTOR switch to FM MONO or AM and tune in an FM monophonic or AM broadcast.
2. Turn the volume control to the right, setting it to a suitable position. Confirm that sound comes from the four speakers (front and rear, left and right). If there is no sound coming from one or more of the speakers, check speaker connections.
3. Turn the BALANCE FRONT-REAR control to the extreme left. At this time, sound should come from the front speakers only.
4. Turn the FRONT BALANCE control to the extreme left and confirm that sound comes from the front left speaker (CH. 1) only. Then turn this control to the extreme right and confirm that sound comes from the front right speaker (CH. 3) only.
5. Turn the BALANCE FRONT-REAR control to the extreme right and confirm that sound comes from the rear speakers alone.
6. Turn the REAR BALANCE control to the extreme left and confirm that sound comes from the rear left speaker (CH. 2) only. Then turn this control to the extreme right and confirm that sound comes from the rear right speaker (CH. 4) only.
7. If checks do not conform, speaker connections may be in error. Recheck them. After confirming that operation is normal, set these controls to mid-positions.

### ADJUSTMENT OF LEVEL BALANCE AMONG 4 CHANNELS

1. Set the VOLUME control to a normal listening level.
2. Depress the REAR buttons of the speaker switches to keep only the speakers (CH. 1 and CH. 3) in the front operating. Turn the FRONT LEFT-RIGHT BALANCE control either way to balance the level between the left and right speakers. Observe the FRONT LEVEL meters.
3. After the level balance for front speaker systems has been adjusted, depress the REAR button once again to return it to ON and depress the FRONT button to keep the speakers (CH. 2 and CH. 4) in the rear operating. Turn the REAR LEFT-RIGHT BALANCE control either way to balance the level between the left and right speakers. Observe the REAR LEVEL meters.
4. After the level balance for the speaker systems in the rear has been adjusted, depress the FRONT button once again to return it to ON. Then, turn the FRONT-REAR BALANCE control either way to balance the level between the speakers in the front and rear.

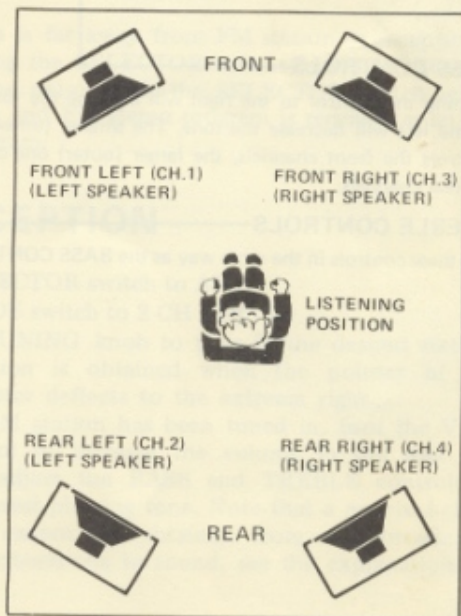

Fig. 10

## FRONT PANEL FACILITIES 2

### FM TUNING METER

Meter for indicating correct FM tuning. After the SIGNAL meter reading has been peaked, adjust tuning so that the pointer of this meter falls at the center mark.

### SIGNAL METER

Indicates the intensity of the received AM or FM radio signal.

### FM STEREO INDICATOR

The lights up when an FM stereo broadcast is being received.

### TUNING KNOB

For tuning in AM and FM stations.

### PROGRAM INDICATORS

Lights up in accordance with the position of the SELECTOR switch.

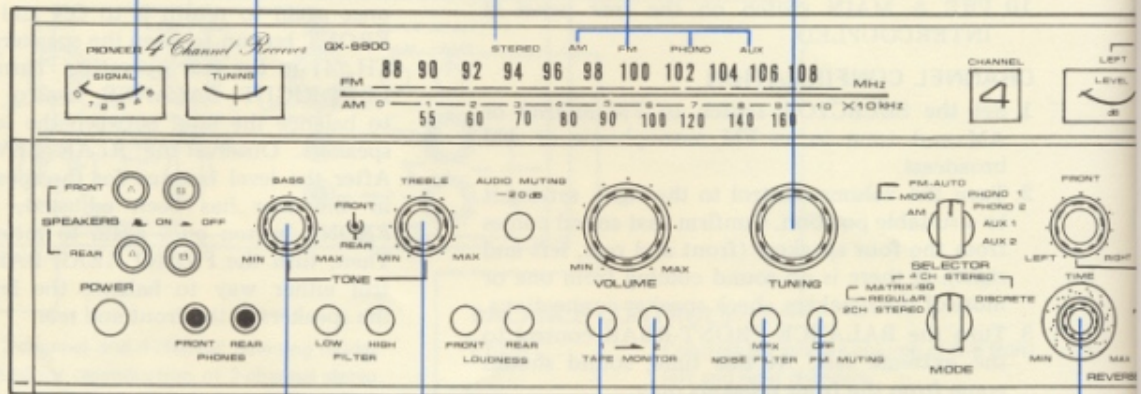

### BASS CONTROLS

Turning the control to the right will increase the tone, and to the left will decrease the tone. The smaller (inner) knob controls the front channels, the larger (outer) one controls the rear channels.

### TREBLE CONTROLS

Use these controls in the same way as the BASS CONTROLS.

### TAPE MONITOR SWITCHES (1 and 2)

These switches are set to ON for checking the recording conditions or for playback with tape decks.

1. This switch is set to ON for monitoring a recording in progress or for playback with a tape deck plugged into the TAPE 1 MON and TAPE 1 REC jacks.
2. This switch is set to ON for checking the recording conditions or for playback with a tape deck plugged into the TAPE 2 MON jacks and TAPE 2 REC jacks.

**NOTE:** For a record playback or listening to broadcasts, leave these switches set to the OFF position. With the switches set to ON no sound will be heard.

### MPX NOISE FILTER BUTTON

Push this button to ON to eliminate high-frequency noise during FM stereo reception.

### FM MUTING BUTTON

In released position, the FM muting circuit cancels out noise on unused FM bands (inter-station noise), but it also rejects very weak, faint FM stations. To receive such a station, push the button to turn off the FM muting circuit.

## FM RECEPTION

### MIC MIXING LEVEL CONTROLS

To add microphone sound to a program, plug one or two microphones into the MIC jacks and turn one or both of these controls clockwise until you obtain the desired balance between microphone sound and the underlying program. If only one microphone is connected, its sound will be heard through both front speakers if the MIC MIXING control for the other channel is at position OFF. To add microphone sound to one channel only, the other control must be turned clockwise, too.

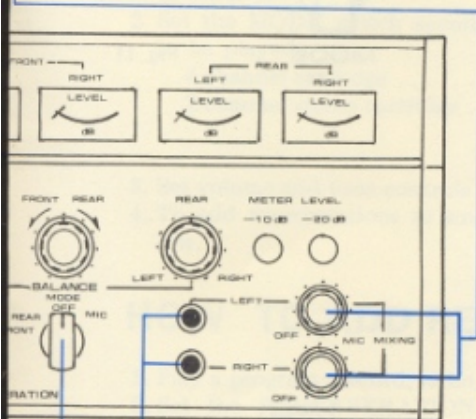

### MIC JACKS (LEFT and RIGHT)

The microphone should be of high impedance.

### REVERBERATION MODE SWITCH

To add a reverberation effect, turn this switch to one of the following positions:

- FRONT . . . . . Reverberation effect only in front channels.
- REAR . . . . . Reverberation effect only in rear channels.
- MIC . . . . . Reverberation added only to microphone sound.

OFF . . . . . No reverberation.

- No reverberation is added to the signals obtainable from the TAPE REC outputs.

### REVERBERATION TIME CONTROL

Used in combination with the REVERBERATION MODE switch. Clockwise rotation causes longer reverberation time, counterclockwise rotation shortens the reverberation time.

1. Set the SELECTOR switch to FM AUTO.
2. Set the MODE switch to 2 CH STEREO.
3. The FM MUTING button to ON (not pushed). If a signal is extremely weak, leave the switch kept to OFF.
4. Turn the TUNING knob to tune in the desired station. Best reception is obtained when the pointer of the SIGNAL meter deflects to the extreme right, while the pointer of the FM TUNING meter indicates the center of the scale. When the tuned-in FM station is broadcasting an FM stereo program, the FM stereo indicator lights.
5. After the FM station has been tuned in, turn the VOLUME control to increase the volume in the way you want, and adjust the BASS and TREBLE controls to obtain the most pleasing tone.
6. If a high-frequency noise is heard during FM stereo reception, push the MPX NOISE FILTER button to eliminate such a noise.
7. Setting the MODE switch to MATRIX-REGULAR or MATRIX-SQ during reception of corresponding FM stereo broadcasts with the use of regular or SQ matrix records permits matrix 4-channel reproduction. These two modes may also be employed during reception of ordinary stereo broadcasts. The result will be an improvement over ordinary 2-channel stereo reproduction. Note that a matrix 4-channel effect cannot be obtained from FM monophonic broadcasts.
8. To add reverberations to sound, see the explanations on page 14.

If your area is far away from FM station or reception is noisy, setting the SELECTOR switch to FM MONO may eliminate the noise. With the SELECTOR switch set to FM MONO, and FM stereo program is received as an FM MONO program.

## AM RECEPTION

1. Set the SELECTOR switch to AM.
2. Set the MODE switch to 2 CH STEREO.
3. Turn the TUNING knob to tune in the desired station. Best reception is obtained when the pointer of the SIGNAL meter deflects to the extreme right.
4. After the AM station has been tuned in, turn the VOLUME control to increase the volume in the way you want, and adjust the BASS and TREBLE controls to obtain the most pleasing tone. Note that a matrix 4-channel effect cannot be obtained from AM broadcasts.
5. To add reverberations to sound, see the explanations on page 14.

## RECORD PLAYING

1. When records are played on the turntable plugged into PHONO 1 jacks, set the SELECTOR switch to PHONO 1. Likewise, when records are played on the turntable plugged into PHONO 2 jacks, set the SELECTOR switch to PHONO 2.
2. Set the MODE switch to match the type of record to be played.  
Regular matrix  
4-channel record . . . . . MATRIX-REGULAR position  
SQ matrix  
4-channel record . . . . . MATRIX-SQ position  
Ordinary stereo record . . . 2 CH STEREO position  
Note that use of MATRIX-REGULAR or MATRIX-SQ position for ordinary stereo records will result in a matrix effect.  
Note that a special decoder is required for playing CD-4 records. When this decoder is employed, set the MODE switch to 4 CH STEREO DISCRETE.
3. Set the VOLUME, BASS and TREBLE controls to desired positions.
4. To add reverberations to sound, see the explanations on page 14.

## USE OF MICROPHONE(S)

1. With both MIC MIXING CONTROL knobs at OFF position, connect one or two microphones to the jacks on the front panel.
2. Turn the MIC MIXING controls slightly clockwise, and speak into the microphone(s). The sound will be heard from the front speakers. Adjust the knobs to obtain the desired microphone sound volume.
3. The master VOLUME control has no influence on the microphone sound.
4. When using microphones, it is advisable to leave the tone controls at or near flat position and the loudness switches off. Otherwise, howling may occur.
5. To add reverberations to sound, see the explanations on page 14 .
  - Keep the microphone(s) as far removed from the loudspeakers as possible.
  - When using only a single microphone, adjust its volume with the respective control. Note, however, that its sound will be reproduced through the other channel speaker, too, as long as the other control is in OFF position. To hear microphone sound through one speaker only, turn the other control knob slightly clockwise.
  - Another program — record, radio, tape — can be played as usual and the microphone sound is blended into it.

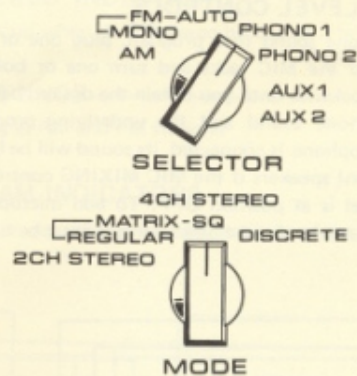

Fig. 11

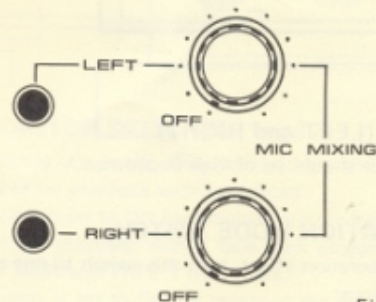

Fig. 12

- The microphones should be high impedance types of over 20 kΩ. Suitable dynamic microphones are available from Pioneer.
- The microphone signal is not available at the TAPE REC outputs and can therefore not be recorded on tape. With a little difficulty, the blended signal can be taken from the PRE OUT outputs and recorded on tape.

## USE OF CARTRIDGE TAPE PLAYER

1. Set the SELECTOR switch to AUX 1. If the tape player is plugged into AUX 2 jacks, set the SELECTOR switch to AUX 2.
2. Set the MODE switch according to the type of cartridge to be played.
  - 4-channel cartridge . . . . . 4 CH STEREO DISCRETE
  - 2-channel stereo cartridge . . MATRIX-REGULAR,  
MATRIX-SQ or  
2 CH STEREO
3. Set volume and tone controls to desired positions.
4. To add reverberations to sound, see the explanations below.

## HOW TO ADD REVERBERATION EFFECT

1. Play a program—record, radio, tape—as usual.
2. Set the REVERBERATION MODE switch at position FRONT or REAR to add reverberations to the front or rear channels, respectively.
3. In position MIC, reverberation effect will be added to the microphone sound only.
4. Now, turn the REVERBERATION TIME control knob clockwise until you obtain the desired reverberation span.
5. To stop the reverberation effect, set the REVERBERATION MODE switch to OFF.

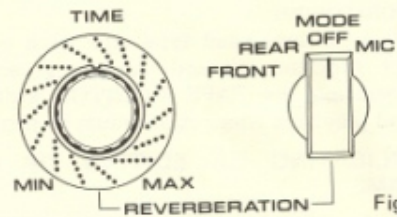

Fig. 13

## USE OF TAPE DECK (OR TAPE RECORDER)

### PLAYBACK

- For using the tape deck plugged into TAPE 1 MON output jacks, set the TAPE MONITOR switch 1 to ON. For using the tape deck plugged into TAPE 2 MON output jacks, set the TAPE MONITOR switch 2 to ON.
- Set the MODE switch according to the type of tape to be reproduced.
 

4-channel discrete tape	4 CH STEREO DISCRETE
2-channel stereo tape	MATRIX-REGULAR
	MATRIX-SQ or
	2 CH STEREO
- Set volume and tone controls to desired positions.
- To add reverberations to sound, see the explanations on page 14.

### RECORDING

As shown in Fig. 14, a signal selected by the SELECTOR switch is always appearing at TAPE 1 REC and TAPE 2 REC jacks. Operate the QX-9900 as described in RECORD PLAYING or FM or AM RECEPTION on pp. 12 & 13.

- NOTES:**
- The MODE switch, VOLUME, BASS, TREBLE controls do not control the signal appearing at TAPE 1 REC and TAPE 2 REC jacks.
  - Control the recording level with the control knobs on the tape deck.

### • MONITORING

When a three-head type tape deck equipped with monitor function is used, recording can be monitored by operating the TAPE MONITOR switch. Both recording and playback connections must be provided.

### DUPLICATING OR EDITING OF RECORDED PROGRAMS

You can make your own "Tape Library" by duplicating or editing recorded programs, using two tape decks combined with the QX-9900. For instance, you can re-record only your favorite parts from an FM stereo program recorded on tape.

- Connect two tape decks as shown in Fig. 15.
- Set the TAPE MON switch 1 to ON, and reproduce a recorded program by operating the tape deck plugged into TAPE 1 MON.
- Record the playback in the way you want by operating the tape deck plugged into TAPE 2 REC (MON). Operating the TAPE MONITOR switch allows you to monitor the recording in progress.

- NOTES:**
- Make sure to set the TAPE MONITOR switch 1 to ON.
  - Recording with a PAUSE switch-provided tape deck will facilitate duplicating or editing of recorded programs.

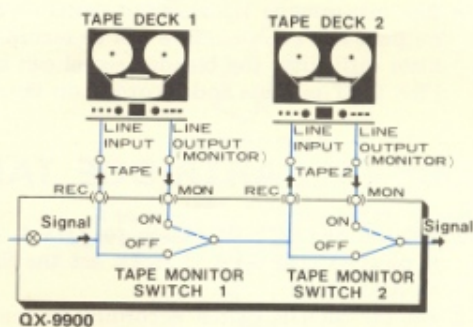

Fig. 14

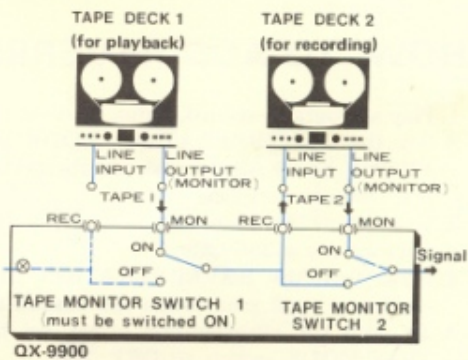

Fig. 15



## SETTING UP A 2-CH. 2-WAY MULTI-AMPLIFIER SYSTEM

By combining separately available electronic crossover network (SF-500 or SF-700) with the QX-9900, a 2-ch. 2-way multi-amplifier system can be set up. Connect the crossover network to the QX-9900 as follows:

1. Set the PRE & MAIN switch on the rear of the QX-9900 to SEPARATED.
2. Connect the input jacks of the crossover network to the PRE OUT jacks of the QX-9900.
3. Connect the MAIN IN jacks (CH. 1 and CH. 3) to the high-range output jacks of the crossover network.
4. Connect the MAIN IN jacks (CH. 2 and CH. 4) to the low-range output jacks of the crossover network.
5. Connect the plug for the tweeter to the speaker sockets CH. 1 and CH. 3, and the plug for the woofer to the sockets CH. 2 and CH. 4.

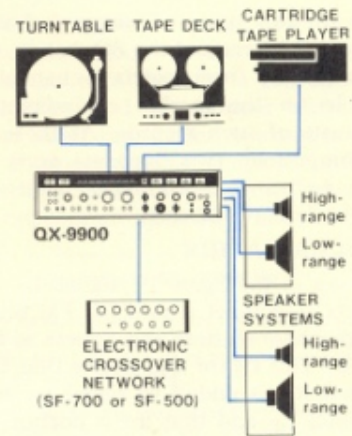

Fig. 16

## MATRIX 4-CHANNEL DECODER

There are two types of matrix 4-channel systems, the regular matrix and the SQ matrix. Signal source comes directly from matrix 4-channel records now available on the market or indirectly from FM broadcasts of such records. As these methods are not compatible, two decoders must be added to obtain 4-channel reproduction which exhibits the inherent features of each.

### REGULAR MATRIX

As shown in the figure 17, signals  $L_T$  and  $R_T$  from a matrix 4-channel record (or FM broadcast) pass through phase shifters and appear as four separate outputs. This figure also shows that the  $\alpha$  portion of signal  $R_T$  is added to signal  $L_T$  to form front left signal  $L_F$  and that the  $\alpha$  portion of signal  $L_T$  is added to signal  $R_T$  to form front right signal  $R_F$ . The  $\beta$  portion of signal  $R_T$  with phase led  $90^\circ$  ( $+jR_T$ ) is added to signal  $L_T$  with phase lagged  $90^\circ$  ( $-jL_T$ ) to form rear left signal  $L_R$ , while the  $\beta$  portion of the  $-jL_T$  signal is added to the  $+jR_T$  signal to form rear right signal  $R_R$ .

$$L_F \text{ (front left, CH. 1): } L_T + \alpha R_T$$

$$R_F \text{ (front right, CH. 3): } R_T + \alpha L_T$$

$$L_R \text{ (rear left, CH. 2): } -jL_T + j\beta R_T$$

$$R_R \text{ (rear right, CH. 4): } +jR_T - j\beta L_T$$

$L_T$  and  $R_T$  are signals from a record or FM broadcast. Term  $-j$  denotes that the phase of the signal has been lagged  $90^\circ$  (with a phase shifter), while term  $+j$  denotes that the phase of the signal has been led  $90^\circ$ .

Using this approach, unnatural images are eliminated and at the same time realism is effected. Even if 2-channel stereo records (FM broadcasts) supply the source material, the resultant effect is an improvement over ordinary 2-channel stereo sound.

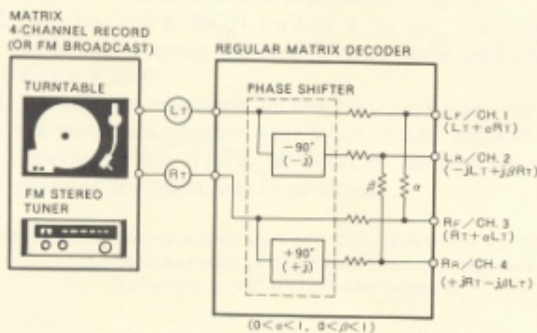

Fig. 17

### SQ MATRIX

As shown in the figure 18, signals  $L_T$  and  $R_T$  from an SQ matrix record (or FM broadcast) pass through phase shifters and appear as four separate outputs. This figure shows that signal  $L_T$  becomes signal  $L_F$  (CH. 1) and that signal  $R_T$  becomes signal  $R_F$  (CH. 3), without any alteration.

A phase shifter lags the phase of signal  $L_T$  by  $90^\circ$ , after which the lagged signal is added to signal  $R_T$ . Level of the resultant signal is dropped by  $1/\sqrt{2} \div 0.7$  and phase is inverted to form  $L_R$  (CH. 2) signal. In the same manner, signal  $L_T$  is added to signal  $R_T$  with phase lagged  $90^\circ$ . The level is reduced by  $1/\sqrt{2}$  to form signal  $R_R$  (CH. 4).

$$L_F \text{ (CH. 1): } L_T$$

$$R_F \text{ (CH. 3): } R_T$$

$$L_R \text{ (CH. 2): } +j0.7L_T - 0.7R_T$$

$$R_R \text{ (CH. 4): } -j0.7R_T + 0.7L_T$$

Thus, it is seen that separation in the SQ matrix system is better than that in the regular matrix system, that is, separation between  $L_F$  and  $R_F$ . A principal feature of the SQ matrix is the use of logic circuitry, a feature which cancels rear center sound when front center sound exists or vice versa. This arrangement also leads to naturalness in reproduction.

In matrix reproduction of 2-channel records (FM broadcasts), front ( $L_F$ ,  $R_F$ ) separation theoretically becomes infinite. At the same time, rear signals are  $90^\circ$  out of phase to front ( $L_F$ ,  $R_F$ ), resulting in a feeling of depth which corresponds to a large hall.

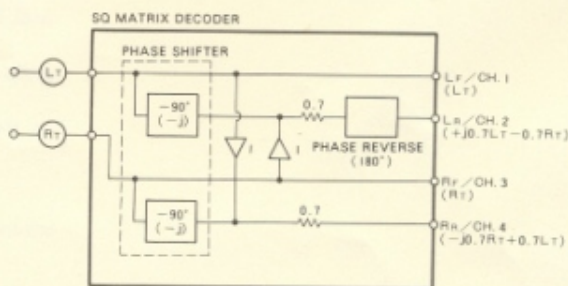

Fig. 18

## CONDITIONS FREQUENTLY MISTAKEN FOR MALFUNCTION

Noise: There are a variety of noises relating to the operation of a hi-fi unit. These are generally divided into two types; (1) the unit is faulty (a transistor or part has deteriorated) and (2) an external source is adding to the unit.

When a hi-fi unit produces an unpleasant noise, it is often assumed that the unit is faulty, but statistical records indicate that the majority of noises pro-

duced in hi-fi acoustic units result from external sources of noise: Due to the inherent high sensitivity and the high fidelity in reproduction, the unit amplifies and reproduces extraneous noises, however small, into definite output noise. If your receiver produces a noise, check according to the following table and trace out the source of noise for the appropriate corrective action.

	SYMPTOM	SUSPECTED SOURCE OF NOISE	DIAGNOSIS AND REMEDY
WHEN LISTENING TO BROADCASTS	Continuous or intermittent noise like jiiiii or zzzzzz.	<ul style="list-style-type: none"> <li>• Static (lightning)</li> <li>• Fluorescent lamp, motor, or thermostat may be in use in house or in the vicinity of the house.</li> </ul>	In many cases, it is very difficult to remove the source of noise. In order to make the radio input larger than the noise level, set up a good outdoor antenna and make a complete grounding.
	When a station is tuned in, hum is mixed in the program.	<ul style="list-style-type: none"> <li>• Poor fluorescent lamp, motor, or electric heater may be in use in house or near the house.</li> </ul>	Reversing the line plug may occasionally alleviate this noise problem. Usually it is very difficult to eliminate the noise.
	Hissing sound noise in AM (medium wave) reception.	<ul style="list-style-type: none"> <li>• The frequency of an adjacent station is interfering with that of the station being tuned in (10kHz beat interference).</li> <li>• TV set is on in the same house with the receiver.</li> </ul>	Impossible to remove such interference. If the cause of such noise is in the TV set, increase the distance between the TV set and receiver.
	Static noise (in particular, when automobiles run close to the house).	<ul style="list-style-type: none"> <li>• White noise generated from automobile engines.</li> <li>• Radio frequency sewing machine or welding machine being used near your house.</li> </ul>	In an area surrounded by hills or high buildings, the FM input signals are very weak. Thus the noise limiter in the circuit loses its function. Set up an FM outdoor antenna having many director elements.
	Reception of FM stereo program contains more noise than FM mono program.	<ul style="list-style-type: none"> <li>• Note that the service area covered by an FM stereo broadcast is about 50% of that of a regular mono broadcast.</li> </ul>	Increasing FM input signal may alleviate this problem. Use an exclusive FM outdoor antenna instead of the indoor T-type antenna.
WHEN PLAYING RECORDS	Hum or buzz. When switched to radio reception, the noise disappears.	<ul style="list-style-type: none"> <li>• Poor connection of shielded wire. (a)</li> <li>• Jack connection is loose. (b)</li> <li>• Line cord or fluorescent lamp is near the shielded wire. (c)</li> <li>• Poor grounding. (d)</li> <li>• Ham transmitting station or TV transmitting station is near your house. (e)</li> </ul>	Correct the conditions stated in (a), (b), (c) or (d). In case of (e), report it to an official activity.
	Output tone quality is poor and mixed with noise. Treble is not clear.	<ul style="list-style-type: none"> <li>• Stylus wears out. (a)</li> <li>• Record wears out. (b)</li> <li>• Dust adheres to stylus. (c)</li> <li>• Stylus is improperly mounted. (d)</li> <li>• Stylus pressure is not proper. (e)</li> <li>• The TREBLE level is too high.</li> </ul>	Check (a) through (e) and correct the condition.  Lower the TREBLE level.

WATCH FOR THE FOLLOWING CONDITIONS; THESE ARE ALSO APT TO BE MISTAKEN FOR MALFUNCTIONS.

	SYMPTOM	SUSPECTED SOURCE OF NOISE	DIAGNOSIS AND REMEDY
	Power is not turned on although the power switch is set to ON.	<ul style="list-style-type: none"> <li>• Fuse blows. (a)</li> <li>• Line plug is loose. (b)</li> </ul>	Check (a) and (b) and correct the condition.
	In playing a record, increasing the volume causes howling.	<ul style="list-style-type: none"> <li>• Distance between the turntable and the speakers is too short.</li> <li>• The place on which the turntable or speakers are set is unstable.</li> </ul>	Change the distance or rearrange the installation increase of the unit and speakers. (Installing the turntable on a firm, solid stand may alleviate this problem.) Do not enhance the BASS sound level excessively.

## SPECIFICATIONS

### SEMICONDUCTORS

FETs . . . . .	8
ICs . . . . .	4
Transistors . . . . .	113
Diodes . . . . .	62

### POWER AMPLIFIER SECTION

Music Power Output (IHF)	240W (4Ω) 180W (8Ω)
Continuous Power Output (1kHz each channel driven)	50W/50W/50W/50W (4Ω) 38W/38W/38W/38W (8Ω)
Continuous Power Output (1kHz 2 channels driven)	45W + 45W/45W + 45W (4Ω) 35W + 35W/35W + 35W (8Ω)
Continuous Power Output (1kHz 4 channels driven)	36W x 4 (4Ω) 30W x 4 (8Ω)
Power Output in the Range of 20Hz to 20kHz (2 channels driven)	33W + 33W/33W + 33W (8Ω, Harmonic Distortion)
(4 channels driven)	28W x 4 (less than 0.5%)
Harmonic Distortion	Less than 0.5% (Continuous Power Output) Less than 0.03% (8Ω, 18W + 18W/18W + 18W Power Output)
Intermodulation Distortion	Less than 0.5% (Continuous Power Output) Less than 0.05% (8Ω, 18W + 18W/18W + 18W Power Output)
Power Bandwidth (IHF) 2 channels driven	5Hz to 80kHz
4 channels driven	5Hz to 70kHz (8Ω, Harmonic Distortion less than 0.5%)
Frequency Response	5Hz to 90kHz, ± 1 dB
Input Sensitivity/Impedance (1kHz Continuous Power Output)	500mV/50kΩ
Speakers	2 pairs for Front, 2 pairs for Rear (4 to 16Ω)
Headphone Jacks	Front and Rear
Damping Factor	50 (8Ω, 1kHz)
Output Level Meters	0 dB = 35W/8Ω (4 channels)

### PREAMPLIFIER SECTION

Output Voltage	500mV (Rated output), 4.5V (Max.)
Harmonic Distortion	Less than 0.5%
Frequency Response	10Hz to 20kHz, ± 1 dB
Input Sensitivity/Impedance (1kHz, for rated output)	PHONO 1 MAG 2.9mV/45kΩ PHONO 2 MAG 2.9mV/45kΩ MIC 3.8mV/50kΩ AUX 1, 2 200mV/60kΩ TAPE MONITOR 1, 2 200mV/60kΩ TAPE REC 1, 2 (Pin jack) 200mV TAPE REC (DIN connector) 35mV
Recording Output	
BASS Control	-10.5 dB, +10.5 dB/100Hz
TREBLE Control	-10 dB, + 9.5 dB/10kHz
LOW Filter	- 8 dB/50Hz (6 dB/oct.)
HIGH Filter	- 8 dB/10kHz (6 dB/oct.)
Equalization Curve	PHONO: RIAA S.T.D.
Loudness Contour	+7 dB/100Hz, +4 dB/10kHz With Volume Control set at -40 dB position.
Muting	-20 dB
Hum and Noise (IHF, Short circuited, A network)	PHONO More than 75 dB. AUX More than 85 dB

**FM TUNER SECTION**

Frequency Range	88MHz to 108MHz
Usable Sensitivity (IHF)	1.8 $\mu$ V
Capture Ratio (IHF)	2 dB
Selectivity (IHF)	More than 70 dB
Image Rejection	More than -85 dB (98MHz)
IF Rejection	More than 100 dB (90MHz)
Spurious Rejection	More than 90 dB (98MHz)
AM Suppression	50 dB
Signal to Noise Ratio	70 dB
Harmonic Distortion	Mono: less than 0.3% (100% Mod.) Stereo: less than 0.5% (100% Mod.)
Tuning Indicator	Signal strength type and Center tuning type
Muting	Switchable to ON-OFF
Stereo Separation	More than 40 dB (1kHz)
Sub Carrier Suppression	More than 50 dB
Noise Filter	Switchable to ON-OFF
Antenna Input	Impedance 300 $\Omega$ balanced and 75 $\Omega$ unbalanced
De-emphasis	75 $\mu$ sec and 50 $\mu$ sec (switchable)

In some countries, model QX-9900 is delivered with a selector switch for adjusting the FM de-emphasis from 50 to 75 $\mu$ sec. If your unit is equipped with such a switch on the chassis, and if the high sound range gives an impression of weakness, move the de-emphasis switch to its other position.

**AM TUNER SECTION**

Frequency Range	525kHz to 1,605kHz
Usable Sensitivity (IHF)	10 $\mu$ V
Selectivity (IHF)	More than 35 dB
Image Rejection	More than 80 dB (1,000kHz)
IF Rejection	More than 75 dB
Signal to Noise Ratio	More than 50 dB
Antenna	Built-in ferrite loopstick antenna

**MISCELLANEOUS**

Power Requirements	110V, 120V, 130V, 220V and 240V (Switchable)
	50-60Hz
Power Consumption	480W (Max.)
AC Outlets	Switched 1, Unswitched 2
Dimensions (overall)	22-1/16 in./560mm (width)
	6-11/16 in./170mm (height)
	16-15/16 in./430mm (depth)
Weight Without package	46 lb 14 oz/21.3 kg
With package	56 lb 12 oz/25.8 kg
Furnished Parts	FM T-type antenna 1
	Speaker plugs 8
	Polishing cloth 1
	Operating instructions 1

**NOTE:** Specifications and the design subject to possible modification without notice due to improvements.